

# ***INVESTOR PRESENTATION 2024***

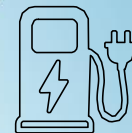

# Contents

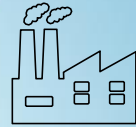

**Overview : An Integrated Electrical, Automation and Electronic Solutions Provider.**



**Marine : Leader in Providing Electrical and Electronic Solutions.**



**Industrial : One of the Largest Manufacturers of LV and MV Switchgear in India.**



**Strong Fundamentals & Focused Growth Strategies.**



**Financial Analysis.**



# ***CORPORATE OVERVIEW***



# Marine Electricals..

Established in 1978, and since then serving the market in diversified areas like Navy & Coast Guard, Commercial Ship Building Yards, Industries and Commercial Establishments, Ports and Electric Vehicles.

Marine Electricals is an integrated technical services provider in the fields of Electrical Automation, Power Electronics, Information and Communication Technology Solutions.

Offers comprehensive range of Electrical Switchgears like MV Panels, LV PCCs iMCCs, Bus Trunking Solutions and Automation Solutions like remote monitoring and control systems, EMS and IBMS to name a few.

Manufactures and installs complete range of slow and fast EV Chargers from 3.3 KW to 240 KW in addition to providing its in-house App Bijlify and charge point management system.

Offers world-wide services with offices and service centres at over 14 key locations in India.

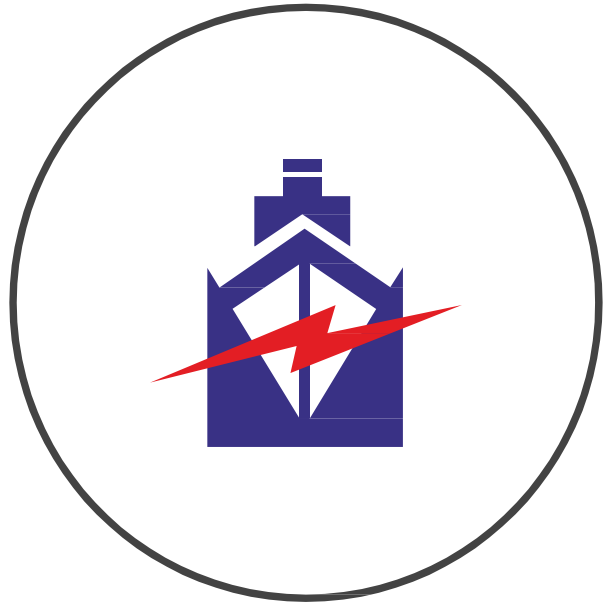

# Servicing with skilled team & wide geographical reach



**+1,000**  
Manpower

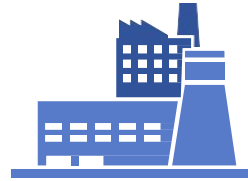

**# 8**  
Manufacturing  
Plants



**# 14**  
Service  
Centres



**# 18**  
Sales and  
Representative offices

- 250+ engineers and a specialised team with Marine experience.
- 60+ shared services & back - office staff.
- 25% women.

Across Goa, Mumbai, Chennai, UAE & Italy.

Across coastal locations in India.

Across India and Middle East.



# Promoters with sound technical background

## Vinay Uchil

Chairman and Executive Director



- A seasoned leader with 29 years of experience spearheading the Marine and Defence segment's growth. Proven track record of fostering business alliances, driving strategic vision, and expanding into new markets.
- Transformed the group into a leading solution provider through unparalleled expertise and cutting-edge technology in electronics, NAVCOM, and new product developments.
- Guided the organization's growth and vision, propelling the Company to become a prominent force in the sector.
- Led successful acquisitions and corporate expansion into the industrial market, driving the company to new heights.
- B.E. in Instrumentation, PGDBA (Finance) from Narsee Monjee Institute of Management Studies (NMIMS).

## Venkatesh Uchil

Managing Director



- Highly motivated and versatile professional with 22+ years of experience in Marine Electricals.
- Possesses in-depth knowledge across various domains, including Marketing, Production Planning, and Industry Segments.
- Proven track record of driving business growth by securing new opportunities in diverse sectors like Data Centers, Metro Rail, and Pharmaceutical industries.
- Successfully qualified the company for automation and power distribution solutions in large-scale projects, demonstrating technical expertise and strategic thinking.
- Holds a B.E. in Electronics & Telecommunications and a PGDFBM from SP Jain Institute of Management & Research, combining strong technical skills with effective business acumen.

## EXPERIENCED & REPUTED BOARD MEMBERS

### Shailendra Shukla

Executive Director



- BE (ECE) and Master's in Administrative Management (Business Administration) from NMIMS.
- Successful business leader in electronics, NAVCOM, and marine solutions including supplies to Aircraft Carrier.

### Tanuja Pudhierkar

Non-executive Non-Independent Director



- Dr. Tanuja is MD in Obstetrics & Gynecology -2002.
- Worked as a consultant at well-known hospital Chains.
- Her contributions to the Company on Health & Hygiene and social welfare is immense.

### Nikunj Mishra

Non-executive Independent Director



- Rear Admiral Mishra is B.Tech from Naval College of Engg. PGDBM from IGNOU & M Tech (CS) from IIT Bombay.
- **Served the Indian Navy** till 2011 & has won many accolades like the Nau Sena Medal.
- Turned around HSL giving a new momentum, as CMD.

### Madan Pendse

Non-executive Independent Director



- Having vast experience of 35 years in Finance & accounting,. Mr. Pendse was associated with **Mazagon Dock** for 28 years.
- Qualified B.com and MBA in Finance.



# Supported by a well experienced management team



## Mr. U. M. Bhakthavalsalan

CFO (Chief Financial Officer)

- 35+ years of experience across diverse manufacturing and services industries, encompassing all aspects of finance, accounting, and compliance.
- Building and leading high-performing finance teams, fostering an innovative and collaborative environment.
- Driving continuous improvement initiatives and streamlining processes. Providing valuable financial insights and strategic guidance to support informed decision-making.
- Passionate about developing the next generation of finance leaders, sharing knowledge and expertise.



## Cdr. Rajiv Malhotra

COO (Chief Operating Officer)

- 40 years experience of which 22 years in the Indian Navy and 18 years with Marine Electricals.
- An alumni from NIT, Suratkal, and IIT Delhi; Cdr. Malhotra has served in Senior Positions across sectors in Naval Design, Production, Quality and Key assignments in the Navy.
- Steered the Operational aspects of Marine and Defence businesses and is a pioneer in propelling 'electronics and Integrated Bridge Systems Business' in Marine Electricals.
- Created new partnerships with leading OEMs to provide Turnkey Solutions.



## Capt. Kamal Yadav

Vice President (Global Sales)

- Enriched by sales experience in electronics, NAVCOM, and software solutions with globally leading Companies, joined Marine Electricals in 2018 to grow the Commercial Marine business globally.
- Sailed as the Captain for many shipping companies.
- Rich track record of Business Development region-wise.



## Cmde. S. K. Patel

Sr. Vice President

- Joined Marine Electricals in 2019, as Sr. V.P. Business Development, Special Projects and Head Electrical-Marine Business.
- 40 years experience of which 25 years in the Indian Navy and 15 years in the leading industries.
- BE (Electrical), Alumni of IIT Madras and MBA.
- Enriched by 5 years R&D at WESEE; 6 years of shipbuilding experience in Russia, 10 years in the Western Fleet, and retired as Principal Director Weapon Equipment at Navy HQ.
- 15 years' industry experience includes Rolta, L&T Defence, Reliance and now at Marine Electricals.



## Cdr. Shami Pujji

President (R&D)

- 45+ years of experience across key domains
- Joined Marine Electricals as the Head of R&D in the year 2014 after successfully leading Motorola (India), Amoeba Telecom, Phillips software, and thereafter promoting his own Company Oriole Technology Solutions (OTS).
- B.Sc.; BE (ETE) and Management education with apex-level assignments in state-of-art technology.
- Has been instrumental in developing a host of products and software solutions for the Indian Navy which commended him for his out-of-the-box innovations.



## Mr. Navin Rao

Vice President Marine (E&A) Business

- 25+ years' of rich experience in Electrical products, processes and classification society as an inspecting surveyor.
- Established & led Goa Operations, reducing lead time by 20%.
- Proven track record of driving process improvements, and achieving results Currently helms Marine Business Unit, driving growth & mentoring teams.
- Demonstrated strong leadership skills in managing multiple manufacturing plants and mentoring a high-performing team across all departments.



# Supported by a well experienced management team



## Dr. T. K. Mani

Head, Product R&D

- Joined Marine Electricals in 2019, as Head, Product R&D at Kochi. He has been Principal of reputed Engineering Colleges, in Kochi. He has a passion for product design. He is Head of Research and Development Centre, at Kochi.
- Under his leadership, niche product developments are being steered for the Company.



## Dr Milind Dalvi

CTO (Chief Technology Officer)

- Experienced engineering professional with 40 years of all-round technical experience, in electrical transmission and distribution equipment.
- Before joining Marine Electricals in 2019, 35 years with Schneider Electric, Crompton Greaves in various technical domains like design, quality, field services, safety, international standards & trainings.
- In-depth technical knowledge on Power and Distribution Transformers, EHV Switchgears, MV and LV Switchboards, Solution Architectures, Control Systems Design.
- Expertise in global technology transfer, new factories set ups , managing operations, Designing and Type testing as per international norms.



## Mrs. Stella D'Souza

GM - Procurement

- With 30+ years of experience, she strategically leads our procurement team, prioritizing value and risk management.
- Under her guidance, we've achieved major cost reductions, formed key supplier partnerships, and stabilized our supply chain.
- Utilizing market expertise and negotiation skills, she drives efficient procurement, directly improving financial health and operational efficiency.



## Mr. Deepak Vaidya

VP Marketing

- 35+ years of well-rounded business experience gained at Schneider Electric and Crompton Greaves, with a focus on India, France, and Asian countries.
- In-depth technical knowledge of electrical distribution networks and international standards.
- Proven track record in sales & marketing management and strategic business planning. Possesses a BE (Electrical) and a PG in Financial Management from Mumbai University, supplemented by global trainings.





# ***Our Business Verticals***

- ◆ **Defence & Marine Solutions**
- ◆ **Industry Solutions**
- ◆ **Vessel Traffic Management System**
- ◆ **Electric Vehicle Charging Solutions**



***Defence &  
Marine  
Solutions***



# Engineering Capabilities in Marine built over years

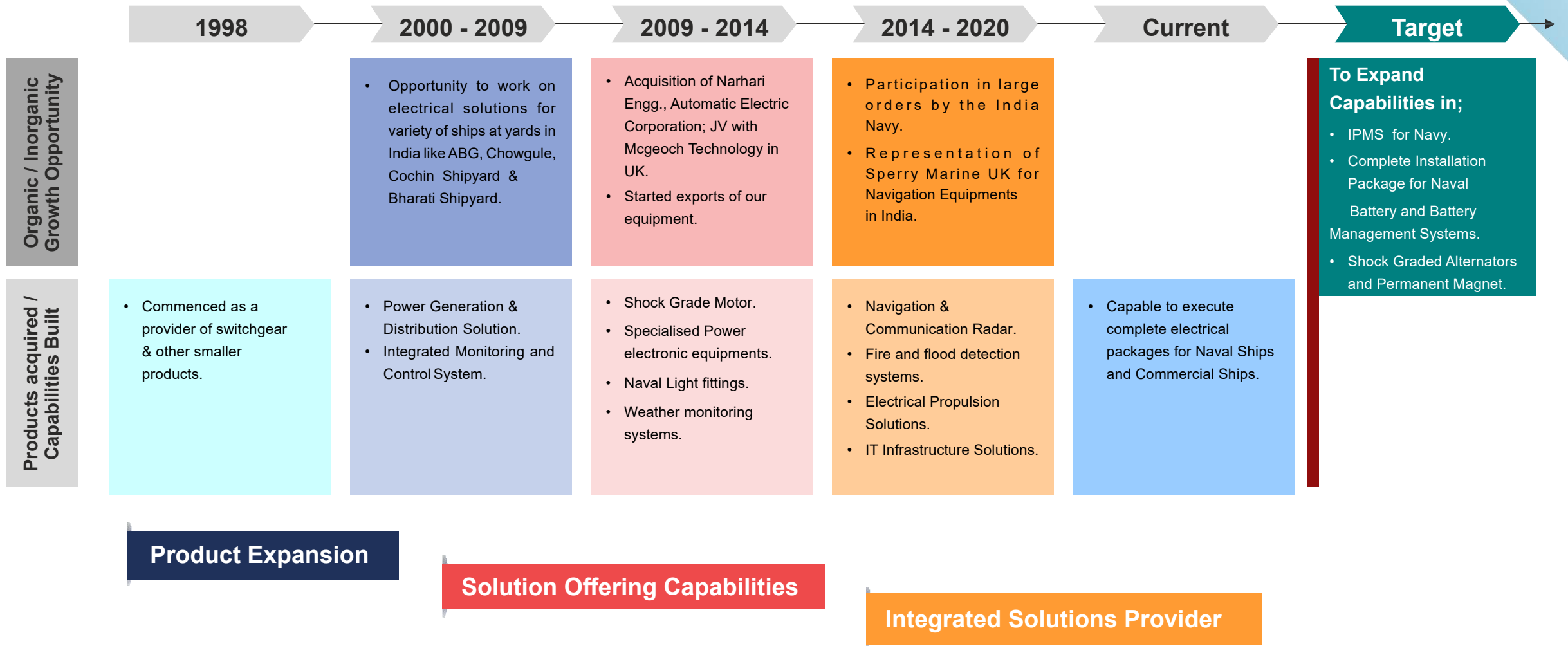

# Defence Solutions

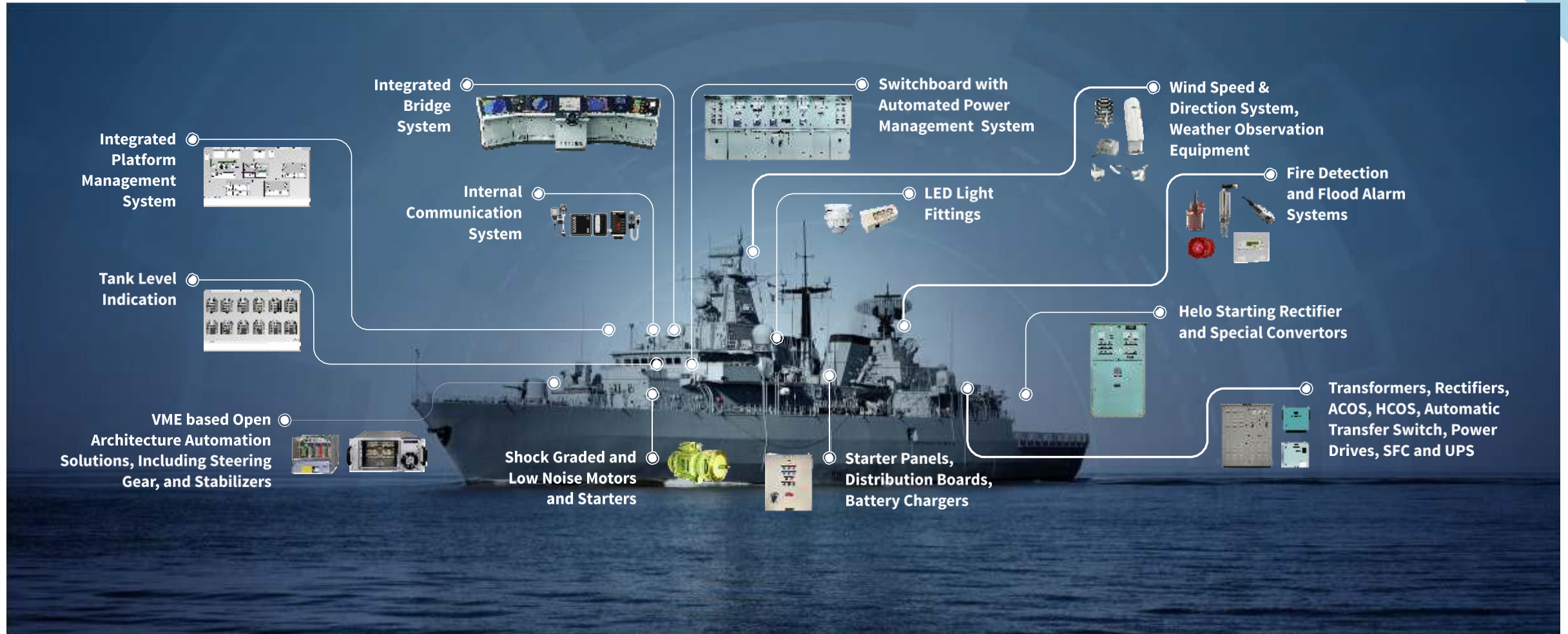

# Commercial and Transport Solutions

**Callouts:**

- Battery Energy Storage System
- LED Light Fittings
- Electric Propulsion Solutions
- Shaft Alternator Solutions
- Fire Detection System
- Navigation and Control System
- Internal Communication System
- Vessel Management System
- Low and Medium Switchboard with Power Management System

**RANGE OF SERVICES**

- Engineering & Consultancy
- Project Management
- Electrical Installation
- Commissioning
- Maintenance
- Spare Parts
- Lifecycle Support

# Our Major Customers : Marine Segment



गोवा शिपयाड"  
लिमिटेड  
Goa Shipyard  
LTD



COCHIN SHIPYARD LIMITED



Hindustan  
Shipyard  
Limited



Technologies



TITAGARH



जी आर एस ई  
CRSE



Shoft Shipyard  
We Promise. We Deliver.



BANGLADESH  
NAVY



एस सी आई  
SCI



CHOWGULE  
GROUP  
SINCE 1916



HEISCO



GRANDWELD  
SHOPYARDS

Zamil  
Shipyards



COLOMB  
O  
DOCKYAR  
D



ओएनजीसी  
ONGC

# Strong track record of Naval and Commercial Vessels

## Defence



### Submarine

- Involved in supply to Scorpene-class vessels for India (Project 75) and Indigenous Nuclear Submarine.



### Frigates and Destroyers

- Working on supply orders for INS Talwar, INS Tabar, INS Brahmaputra, INS Betwa and INS Beas.
- Supplying equipment to Project 17A and P15B class ship.



### ASW Corvettes

- Working for orders from INS Kukri, INS Kuthar, INS Kora and INS Kirch.
- Supplying equipment to CSL and GRSE for 16 anti-submarine Corvettes.



### Aircraft Carrier

- Retrofitting electrical equipment onboard for INS Viraat.
- Supplying equipment for INS Vikrant.



### Indian Coast Guard

- Working on repair work for ICGS Samar, ICGS Sankalp and ICGS Vishwast class of ships.
- Supplying to under construction vessels in GSL, GRSE.



### Survey Vessels

- Working on INS Jamuna, INS Darshak and INS Sarveshak.
- To participate in recent orders to GRSE for 4 Survey Vessels.

## Commercial



### Merchant

- Worked on various ships like Bulkers and tankers, Cargo vessels, Container vessels, Large gas carriers, Special vessels, Tugs etc.



### Passenger

- Worked on various ships like Cruise, Ferry, Yachts etc.
- Supplying complete battery propulsion package to Battery operated ferries.



### Offshore

- Worked on various Offshore projects like Oil and Gas, Port.
- Working of supplying complete propulsion package including batteries for battery electric tug as the government green port program.

# ***Industry Solutions***





# Industrial Solutions : Journey to Turnkey Solution provider

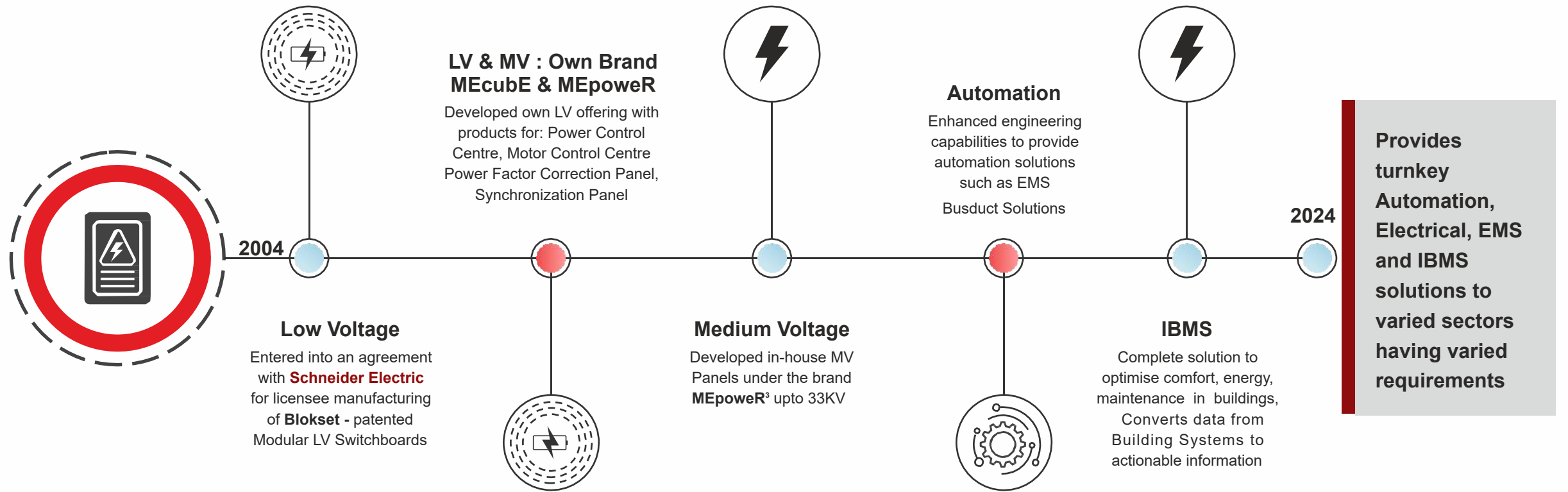

# Industry Solutions



**MECUBE+**  
LV Switchboard



**MEPOWER+**  
MV Switchboard



**Blokset**  
LV Switchboard



**MECONNECT+**  
Smart Connectivity Solutions  
Energy Management Solutions



**BUSDUCT**



**Integrated Building  
Management System**

# Our Major Customers : Industry Segment



# Industry Solutions

## Datacentres



- Achieved **leadership position** in Data Centres.
- **Repeat orders** from marquee clients like Adani Connex, Web Werks, STT, Bridge Data Centres, Netmagic, PDG and other global companies like Equinix and BAM –DLR entering India.
- Indian Data Centre Market witnessing strong growth.
- Strategy to strengthen position by adding capabilities & emerge as an Integrated Solution Provider with quality performance.

## Industrials



- Traditionally strong in **Pharma (USFDA requirement)**, **Automobile** although not sector dependent.
- Seeing growth in Steel, Cement and Chemical both in green-field and brown- field expansion.
- Large projects in green field plants set up to build electronics like phones and semiconductor chips.
- **Clients with Repeat business** : Cipla, MRF, Thermax & Bluestar.

## High Rise Buildings



- Currently involved in the electrical works related to LV & MV panels and Automation system.
- Shift from conventional cables to Busbars as it offers higher safety and lower life cycle cost especially for large complexes.
- MEL's reference list: **Lodha World One, Lodha World Crest, Omkar Alta Monte.**
- PROVIDING SOLUTIONS FOR high potential **Building Management Systems (BMS).**

***Vessel Traffic  
Management  
System***



# Efficient Monitoring of Ports Worldwide



- Xanatos Marine, with headquarters in the West Coast of Canada, was established in 1984 and has grown into one of the world's leading developers of Maritime Domain Awareness (MDA) systems based on the mission- proven TITAN software.
- Over the past 30 years, Xanatos Marine has sold numerous systems globally. These systems and sensors include Coastal Monitoring Systems for National Security, Port/Harbour VTS and VTMIS Systems for safety, security and environmental stewardship, shore based AIS networks, and vessel based ECS systems.
- Since 2023, Marine Electricals has held a majority stake in Xanatos Marine with the aim of providing an indigenous solution to meet the demands of the vast Indian Coast. India is positioned to be the global center of manufacturing, therefore trade from the country is likely to rise many times over, boosting the need for ports and other infrastructure.



The background of the image is a dark, grayscale photograph of an electric vehicle's charging port. A charging cable is plugged into the port, and the surrounding area shows the vehicle's body panels and a protective cover. On the right side of the image, there is a large, light blue graphic consisting of several rounded, diamond-shaped polygons arranged in a cluster, resembling a stylized flower or a modern logo element.

***Electric  
Vehicle  
Charging  
Solutions***

# Lets Bijlify India

## Covering every touchpoint of the EV Ecosystem



In-house hardware and software capabilities



Complete turnkey solutions for end to end project management



Full range of AC & DC fast chargers



OCPP compliance



Customized solutions for commercial, residential and public spaces



Smart, Fast, Cost-Effective



Pan India Service network



# Lets Bijlify India

**Hardware + Software + UI & UX**

*With specialised resources to deliver cutting edge performance.*

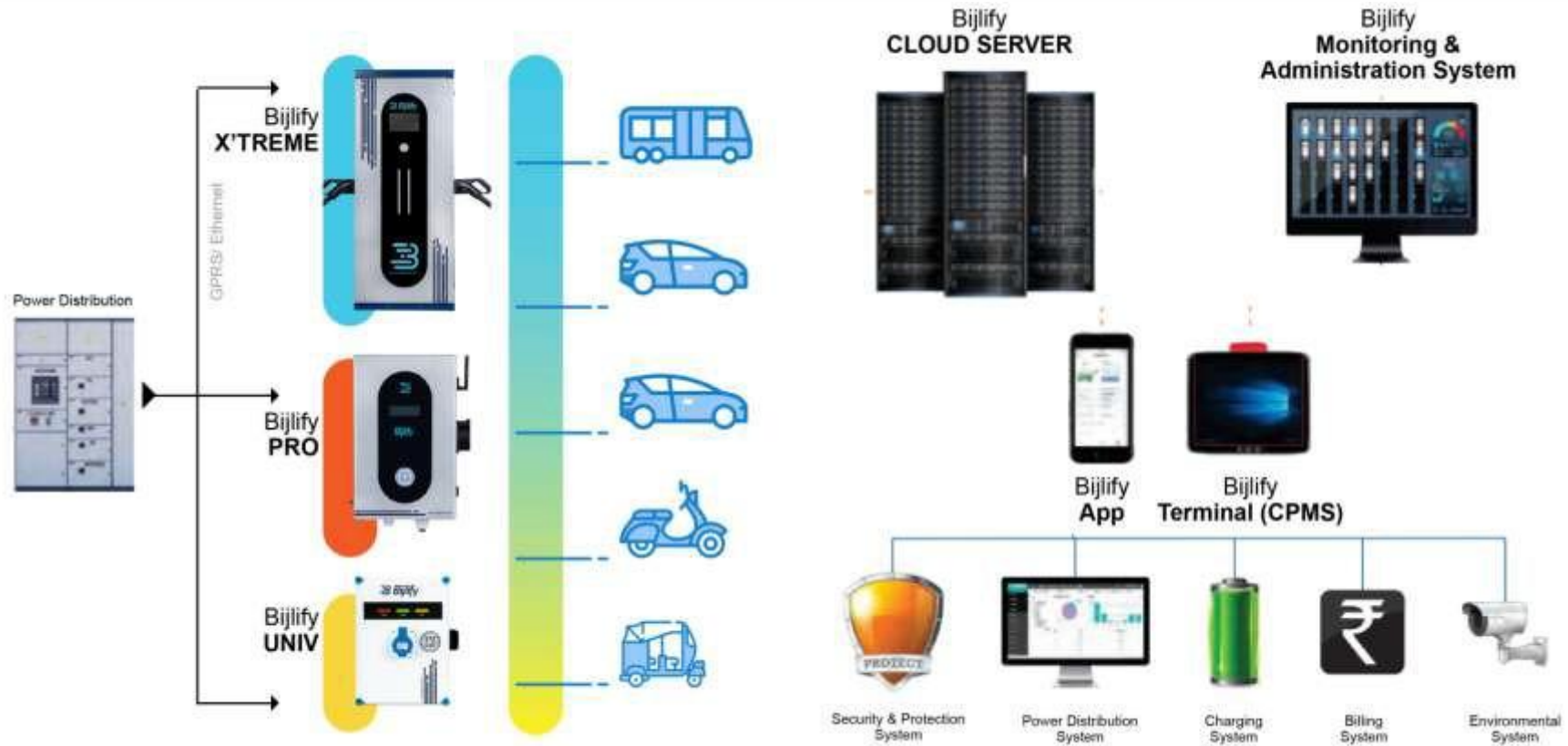

# ***Manufacturing Infrastructure***



# Manufacturing Infrastructure



**Corporate Office in Mumbai**

**Production Plants in Goa, Italy & UAE**



# ***Strengths & Growth Areas***



# Uniqueness - Strengths



**Marine Electricals**



## Leadership in Marine Business

~ 50% market share in the electrical segment

Tier - I electrical supplier & in the **Approved List of Vendors** with Indian Navy, Indian and Global Shipyards.



## High Entry Barrier in Marine

Vendor qualification requires prior experience of similar work, references etc.

Senior Team with relevant experience of working culture of Indian Navy & Shipyards.

Service Infrastructure built across all major ports & Naval establishments.



## Largest Partner of Schneider Electricals in India

50% + market share in Schneider Electrical's Blokset Panels supplied in India.

**Maintains Client Ownership** as experienced Sales Team originates Orders and manages relationships thereafter.

**Repeat Orders** from Marquee Clients testimony of Quality Performance, Timely Delivery and Strong relationships.



## Known Brand Name for Most Reliable & Complex Solution

Leadership in fast growing **DATA CENTRE** segment, where uninterrupted power is very crucial.

Electrical Supplier for Plants of reputed Companies like MRF, Cipla, Asian Paints.



**Marine Electricals™**

[www.marineelectricals.com](http://www.marineelectricals.com)



# The path of growth

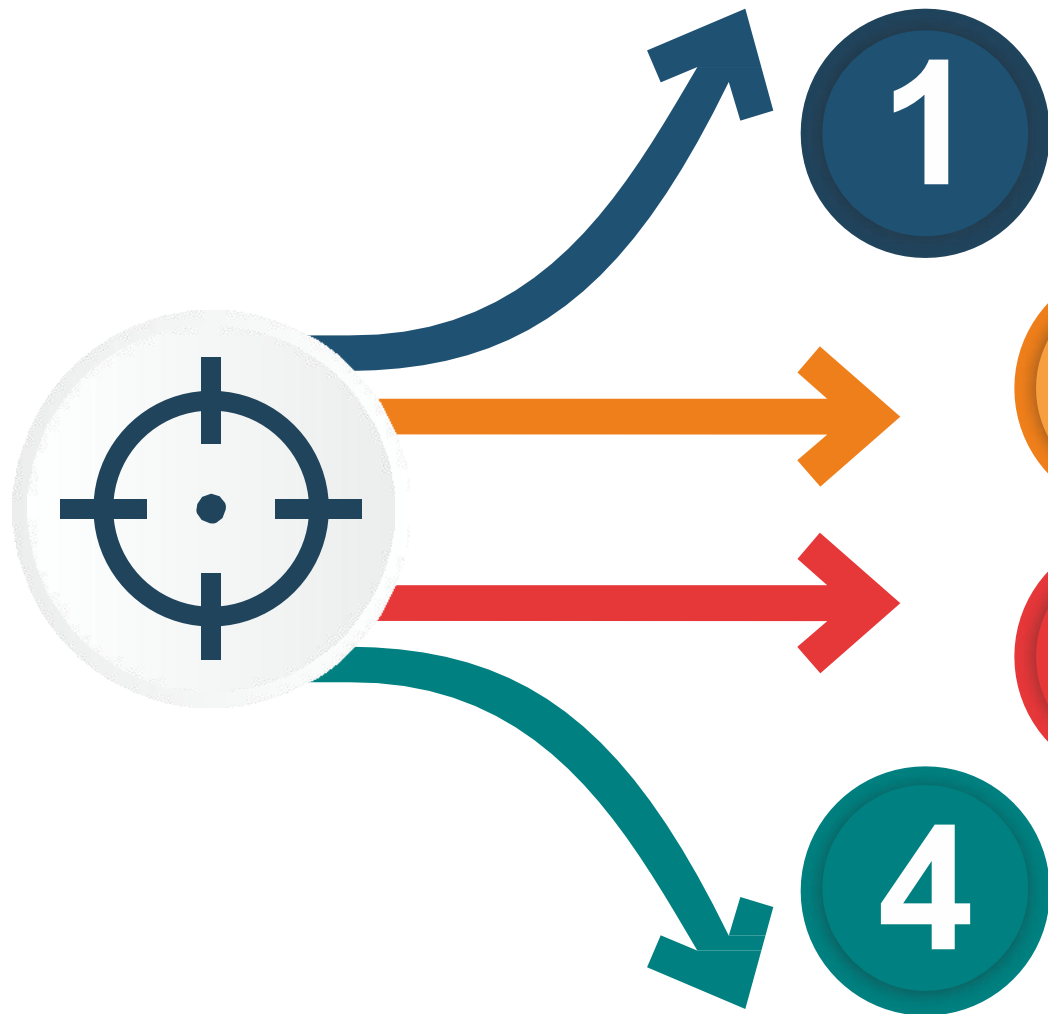

## Expanding Solution Offerings in Marine

- Foray into VTMS and expansion into offshore solutions.
- Foray into offering remote service solutions for maritime industry.
- Focus on scaling up offerings in electrical and hybrid propulsion, IPMS, Navcom, and embedded integrated maritime products and solutions for commercial and defence segments.
- Targeting to receive Service Contract for Weapon Systems.

2

## Expanding Solution offerings in Industry

- Foray into integrated powering solutions for Data centres, Commercial, Industry, and Infrastructure.
- Expanding product offering for manufacturing and data centres segments.

3

## Geographical Expansion & Strategic Empowerment

- Scaled up manufacturing capacity .
- Scaled up research, manufacturing capacity and development for marine segment.
- Scaled up Intellectual capital by adding diverse and talented workforce across all business segments.

4

## EV Charging Solutions

- The unique position of providing complete EV Charging Ecosystem in-house.
- Providing EV Charging solutions with Pune Municipal Corporation (PMC) on a partnership model and looking to expand the same in other cities.
- Focusing on residential and commercial complexes that have to mandatorily provide EV charging provisions in their complexes.



# ***Financial Facts & Figures***



# Financial Facts & Figures

## Company Financials (Standalone)

Revenue (₹ in Lacs)

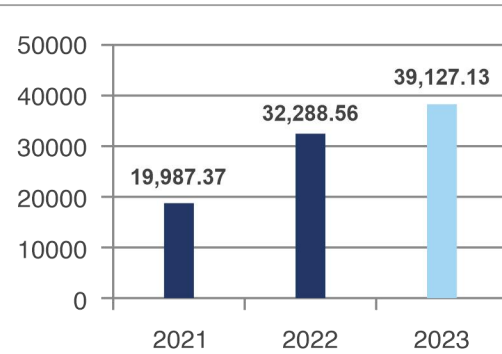

EBITDA (₹ in Lacs)

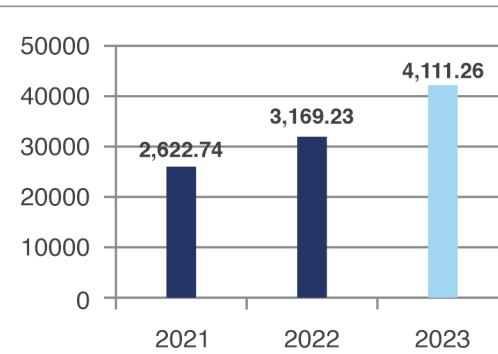

PAT (₹ In Lacs)

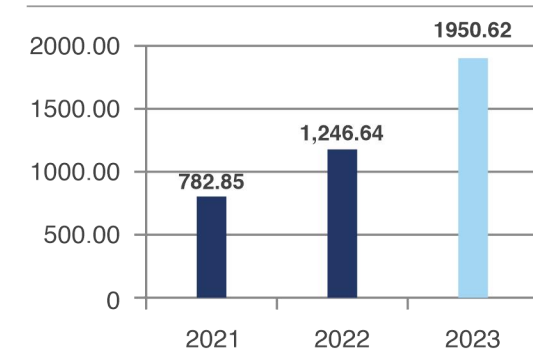

Net worth (₹ In Lacs)

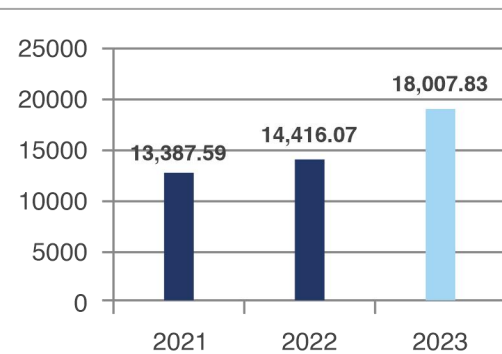

Gross Debt (₹ In Lacs)

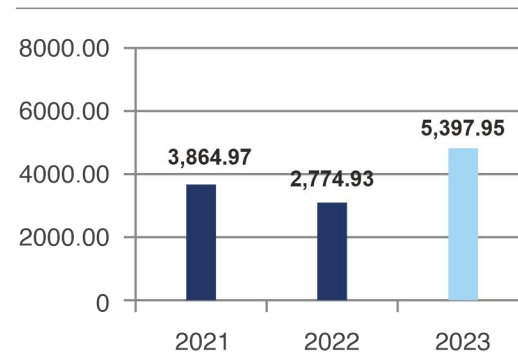

Gross Debt : Equity (X) (₹ In Lacs)

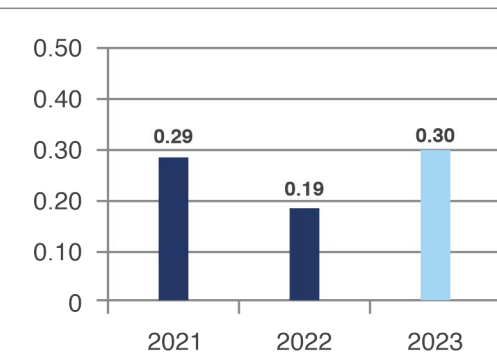



# Financial Facts & Figures

## Company Financials (Standalone)

Listed Company in  NSE

	(₹ In Lacs)		
	FY 2023	FY 2022	FY 2021
<b>Income</b>			
Revenue from operations	39,127.13	32,288.56	19,987.37
Marine Industry	19,807.75	12,794.90	9,834.47
	19,319.38	19,493.67	10,152.90
<b>Total income</b>	<b>39,127.13</b>	<b>32,288.56</b>	<b>19,987.37</b>
<b>Expenses</b>			
Raw Material	29,620.54	24,669.90	14,236.84
Employee benefits expense	2,567.32	2,239.79	1,764.01
Other expenses	3,441.41	2,759.88	1,722.72
<b>Total expenses</b>	<b>35,629.27</b>	<b>29,669.57</b>	<b>17,723.57</b>
<b>EBIDTA</b>	<b>3,497.86</b>	<b>2,618.99</b>	<b>2,263.80</b>
Other income	613.40	550.23	358.94
Finance costs	-862.15	-645.18	-772.56
Depreciation and amortization expense	-612.57	-760.33	-764.36
Income tax expense / (credit):	-685.92	-517.07	-302.97
<b>Profit after tax</b>	<b>1,950.62</b>	<b>1,246.64</b>	<b>782.85</b>

Order Book- Rs. 497 Cr.

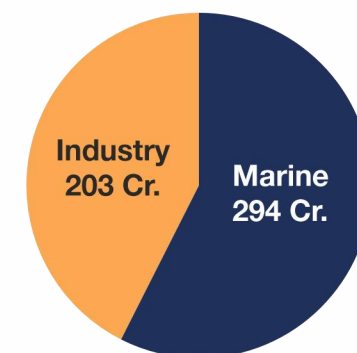

# Financial Facts & Figures

## Company Financials (Standalone)

	(₹ In Lacs)		
	FY 2023	FY 2022	FY 2021
Share capital	2,526.31	2,453.31	2,453.31
Other equity	15,481.52	11,962.76	10,934.28
<b>Total equity</b>	<b>18,007.83</b>	<b>14,416.07</b>	<b>13,387.58</b>
Long term borrowings	1,800.76	439.26	850.02
Other liabilities	165.27	59.57	132.04
long term provisions	322.17	286.77	229.12
<b>Total non-current liabilities</b>	<b>2,288.20</b>	<b>785.60</b>	<b>1,211.18</b>
Short term borrowings	3,597.19	2,335.67	3,014.94
Trade payable	10,542.41	8,032.98	9,021.27
Short term provision	16.76	22.79	24.24
Other financial liability	312.41	611.83	1,062.03
Other liabilities	2,468.03	1,752.67	2,041.78
<b>Total current liabilities</b>	<b>16,936.80</b>	<b>12,755.94</b>	<b>15,164.26</b>
<b>Total liabilities</b>	<b>19,225.00</b>	<b>13,541.54</b>	<b>16,375.44</b>
<b>Total equity and liabilities</b>	<b>37,232.83</b>	<b>27,957.61</b>	<b>29,763.02</b>

## Listed Company in NSE

	(₹ In Lacs)		
	FY 2023	FY 2022	FY 2021
Property, plant and equipment	2,980.65	2,883.90	2,626.37
Right-to-use asset	306.22	397.38	676.46
Capital work-in-progress	-	198.79	-
Investment property	503.81	511.96	572.52
Other intangible assets	154.04	45.63	66.04
Investments	2,562.85	919.46	1,113.49
Other financial assets	2,083.31	360.07	627.56
Other non-current assets	1,542.80	994.87	36.09
Non-current tax assets (net)	71.47	138.18	152.62
<b>Total non-current assets</b>	<b>10,205.15</b>	<b>6,450.23</b>	<b>5,871.15</b>
Inventories	4,441.66	5694.44	5,858.80
Financial assets			
Trade receivables	17,438.04	11915.54	12,705.03
Cash and cash equivalents	11.81	23.64	89.40
Bank balances other than cash and cash equivalents above	1,601.60	744.16	916.60
Other financial assets	980.98	683.11	356.52
Other current assets	2,553.59	2446.48	3,965.53
<b>Total current assets</b>	<b>27,027.68</b>	<b>21,507.37</b>	<b>23,891.89</b>
<b>Total assets</b>	<b>37,232.83</b>	<b>27,957.60</b>	<b>29,763.05</b>



# Financial Facts & Figures

## Company Financials (Consolidated)

Revenue (₹ in Lacs)

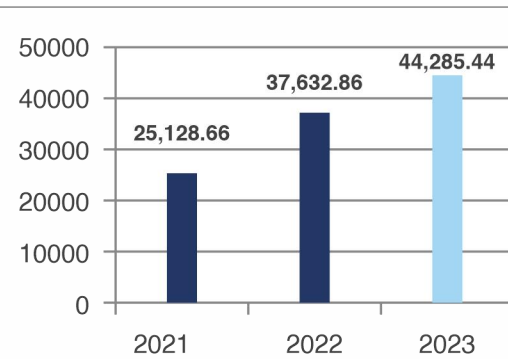

EBITDA (₹ in Lacs)

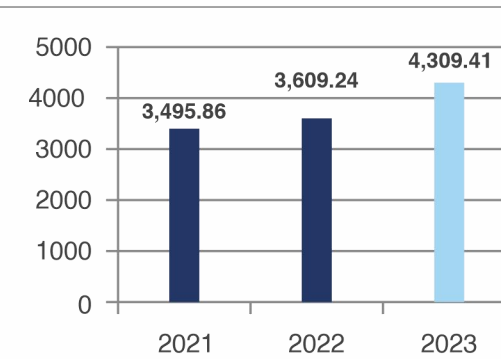

PAT (₹ In Lacs)

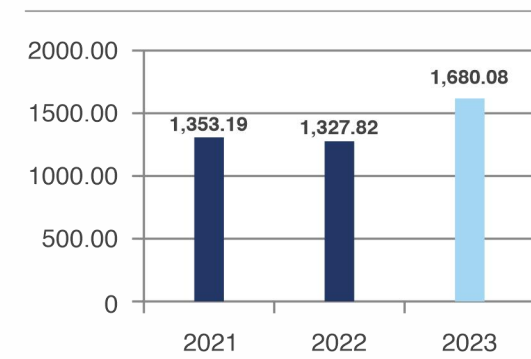

Net worth (₹ In Lacs)

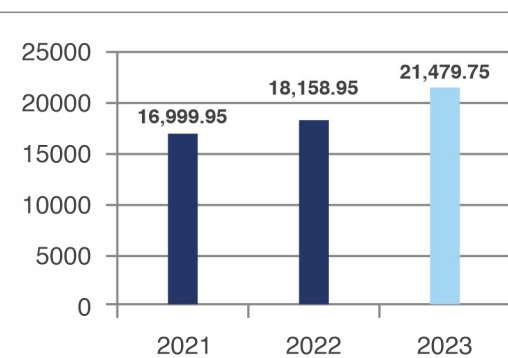

Gross Debt (₹ In Lacs)

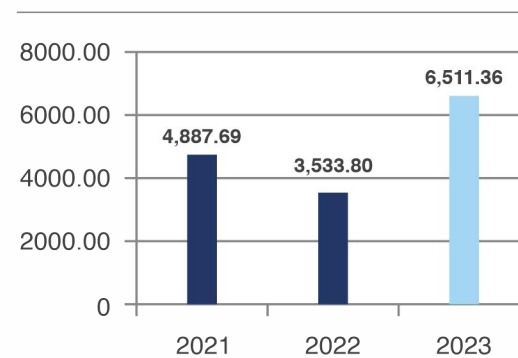

Gross Debt : Equity (X) (₹ In Lacs)

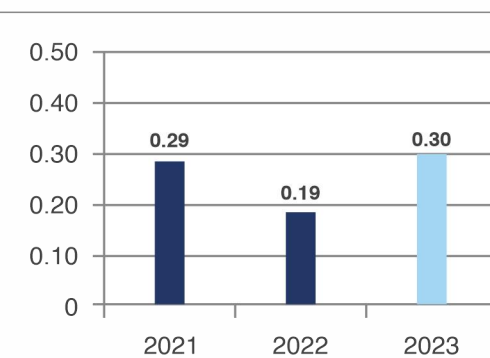

# Financial Facts & Figures

## Company Financials (Consolidated)

Listed Company in  NSE

	(₹ In Lacs)		
	FY 2023	FY 2022	FY 2021
<b>Income</b>			
Revenue from operations	44,285	37,633	25,129
Marine	24,966	18,139	14,976
Industry	19,319	19,494	10,153
<b>Total income</b>	<b>44,285</b>	<b>37,633</b>	<b>25,129</b>
<b>Expenses</b>			
Raw Material	32,968	28,330	17,391
Employee benefits expense	3,450	3,083	2,534
Other expenses	4,011	3,096	2,480
<b>Total expenses</b>	<b>40,429</b>	<b>34,509</b>	<b>22,406</b>
<b>Profit before share in profit / (loss) of associates &amp; joint ventures and tax</b>	<b>3,857</b>	<b>3,124</b>	<b>2,723</b>
Share in profit / (loss) of associates and joint ventures (net of tax, if any)	-	-2	-
<b>EBIDTA</b>	<b>3,857</b>	<b>3,121</b>	<b>2,723</b>
Other income	453	485	773
Finance costs	-994	-728	-893
Depreciation and amortization expense	-808	-935	-912
Income tax expense / (credit):	-827	-616	-338
<b>Profit after tax</b>	<b>1,680</b>	<b>1,328</b>	<b>1,353</b>



# Disclaimer

- This Presentation and the accompanying slides, which have been prepared by Marine Eleactricals (India) Limited , have been prepared solely for information purposes and do not constitute any offer, recommendation or invitation to purchase or subscribe for any securities, and shall not form the basis or be relied on in connection with any contract or binding commitment whatsoever. No offering of securities of the Company will be made except by means of a statutory offering document containing detailed information about the Company.
- This Presentation has been prepared by the Company based on information and data which the Company considers reliable, but the Company makes no representation or warranty, express or implied, whatsoever, and no reliance shall be placed on, the truth, accuracy, completeness, fairness and reasonableness of the contents of this Presentation. This Presentation may not be all inclusive and may not contain all of the information that you may consider material. Any liability in respect of the contents of, or any omission from, this Presentation is expressly excluded.
- Certain matters discussed in this Presentation may contain statements regarding the Company's market opportunity and business prospects that are individually and collectively forward-looking statements. Such forward-looking statements are not guarantees of future performance and are subject to known and unknown risks, uncertainties and assumptions that are difficult to predict. These risks and uncertainties include, but are not limited to, the performance of the Indian economy and of the economies of various international markets, the performance of the industry in India and world-wide, competition, the company's ability to successfully implement its strategy, the Company's future levels of growth and expansion, technological implementation, changes and advancements, changes in revenue, income or cash flows, the Company's market preferences and its exposure to market risks, as well as other risks. The Company's actual results, levels of activity, performance or achievements could differ materially and adversely from results expressed in or implied by this Presentation. The Company assumes no obligation to update any forward-looking information contained in this Presentation. Any forward-looking statements and projections made by third parties included in this Presentation are not adopted by the Company and the Company is not responsible for such third party statements and projections.





# *Thank You*

*Follow*



[www.marineelectricals.com](http://www.marineelectricals.com)

